



**04** ELBA

**06** AMALFI

**08** QUEEN

**10** ZANTE

**12** GOLDWINE

**14** GENOVA BT H180

**16** ISEO TN

**18** ISEO BT

**20** ZERMATT

**22** ARONA

**24** EXCELSIOR

**26** CLICK

**28** PANAREA HD

**30** PANAREA BMM

**32** PANGEA

**34** STAR

#### TECHNICAL FEATURES



**Plug-in**  
Con gruppo incorporato



**Remote**  
Senza gruppo incorporato



**Ventilated**  
Refrigerazione ventilata



**Low consumption fans**  
Ventole a basso consumo



**LED lighting**  
Illuminazione LED



**Off-cycle defrost**  
Sbrinamento a fermata



**Electric defrost**  
Sbrinamento elettrico



**Antifog ventilation**  
Ventilazione antiappannante



**Antifog heater**  
Resistenza anticondensa



**Propane refrigerant gas R290**  
Refrigerante R290

#### COMMERCIAL CATEGORIES



**Sausages & Salami**  
Salumi



**Packed meat**  
Carne confezionata



**Cheese, dairy**  
Formaggi, latticini



**Milk**  
Latte



**Delicatessen**  
Gastronomia



**Vegetables**  
Verdura



**Fruit**  
Frutta



**Snack and Sandwiches**  
Snack e panini



**Impulse**  
Acquisto d'impulso



**Food to go**  
Cibo da asporto



**Dry pastries and bread**  
Pasticceria secca e pane



**Chilled drinks**  
Bibite fresche



**Beer and wine**  
Birra e vino



**Cakes and baked delicacies**  
Torte e prodotti da forno



**Ready meals and salads**  
Piatti pronti e insalate



**Frozen food**  
Surgelati

# PRODUCTS

# LEGENDA



# ELBA BT / TN

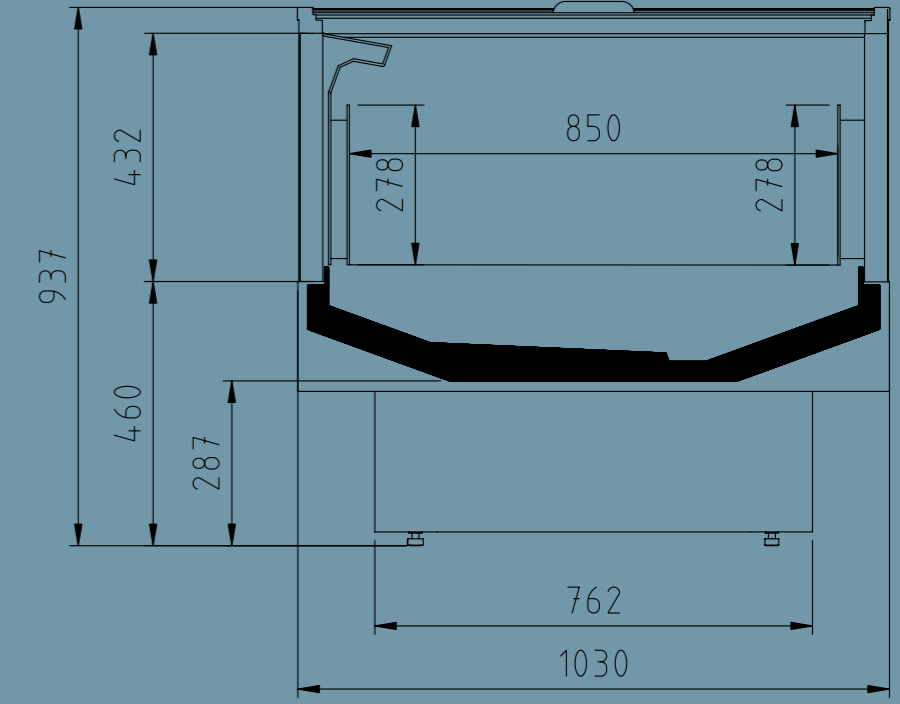
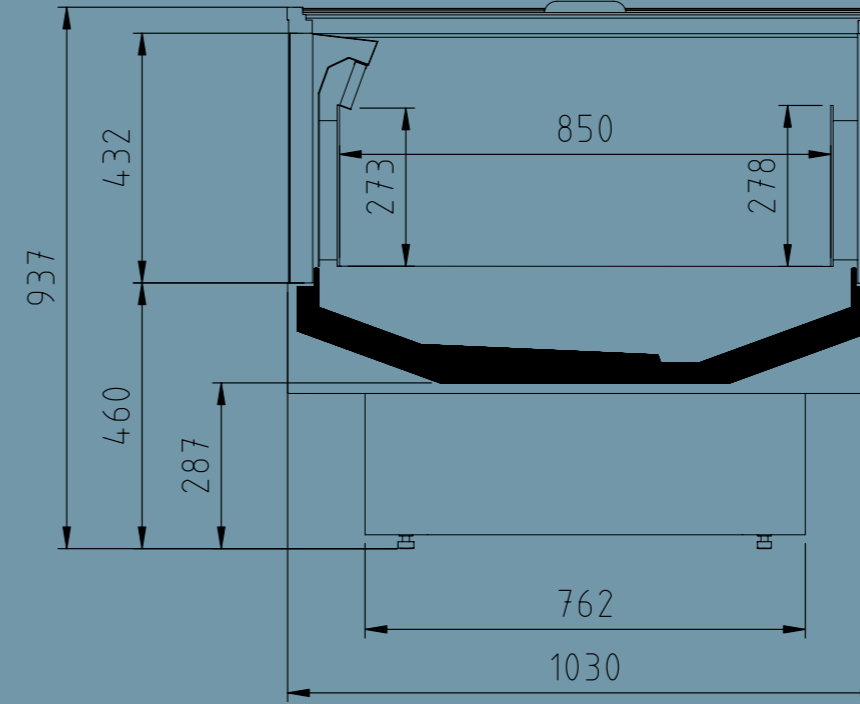

# TECH SPECS

### COMMERCIAL CATEGORIES



### TECHNICAL FEATURES



### AVAILABLE DIMENSIONS

L: 1030 - 1470 - 1910 - 2090 - 2530

### REFRIGERANT

Thermostatic expansion valve for all the refrigerant in use  
Co2 Refrigeration  
R290 built in unit  
Available with all the other refrigerant in use

### AVAILABLE VERSIONS

**Dual Temperature** - Doppia Temperatura



# AMALFI

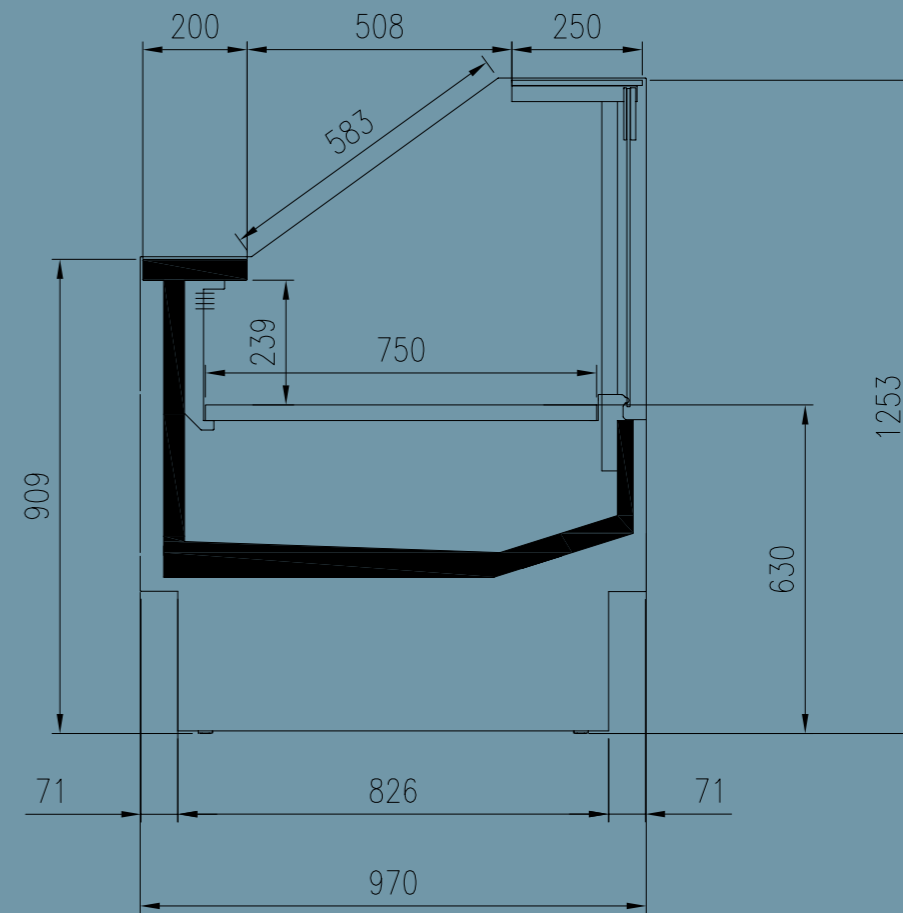

# TECH SPECS

### COMMERCIAL CATEGORIES



### TECHNICAL FEATURES



### AVAILABLE DIMENSIONS

L: 937 - 1250 - 1875 - 2500 - 3125 - 3750

### REFRIGERANT

Thermostatic expansion valve  
for all the refrigerant in use  
Co2 Refrigeration  
R290 built in unit  
Available with all the other refrigerant in use



# QUEEN

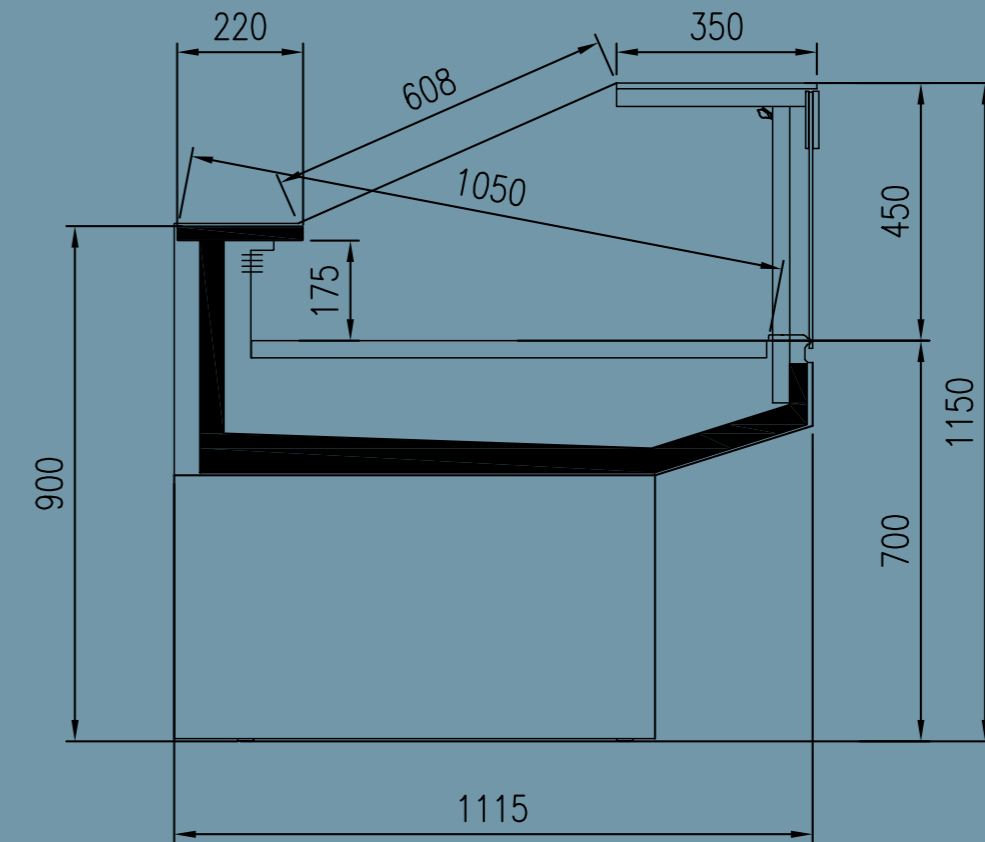

# TECH SPECS

### COMMERCIAL CATEGORIES



### TECHNICAL FEATURES

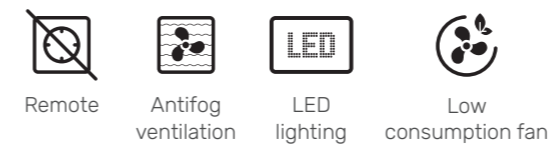

Remote Antifog ventilation LED lighting Low consumption fan

### AVAILABLE DIMENSIONS

L: 937 - 1250 - 1875 - 2500 - 3125 - 3750  
90° INT/ EXT - 45° INT/ EXT

### REFRIGERANT

Thermostatic expansion valve for all the refrigerant in use  
Co2 Refrigeration  
R290 built in unit  
Available with all the other refrigerant in use

### AVAILABLE VERSIONS

**Double Static** - Doppio Statico  
**Fish** - Pesce  
**Pastry** - Pasticceria  
**Bread** - Pane  
**BMM Semivertical multideck**  
BMM Murale semiverticale



# ZANTE

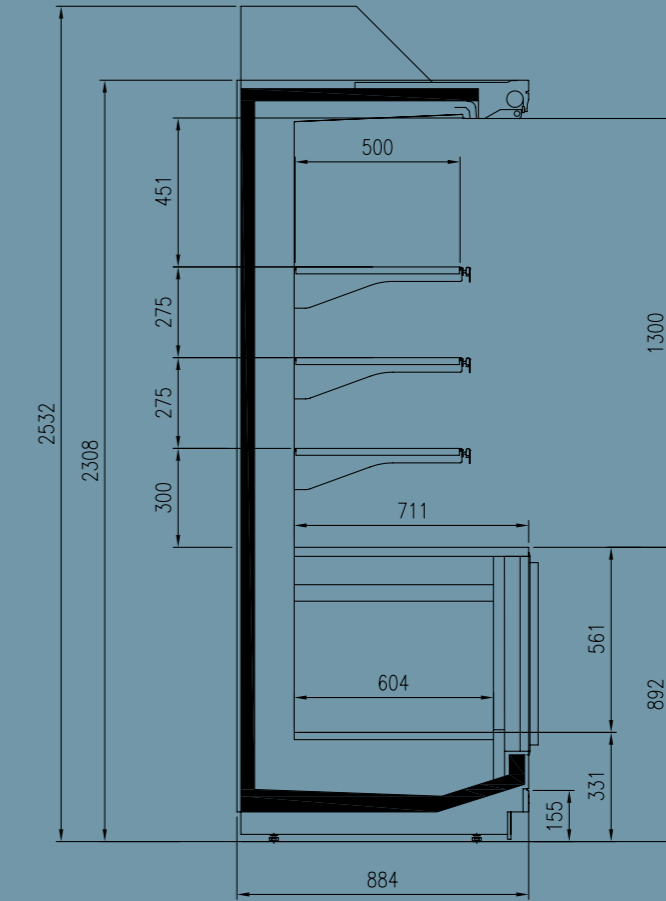

# TECH SPECS

### COMMERCIAL CATEGORIES



### TECHNICAL FEATURES



### AVAILABLE DIMENSIONS

L: 1250 - 1875 - 2500  
D: 85  
H: 216 - 230

### REFRIGERANT

Thermostatic expansion valve for all the refrigerant in use  
Co2 Refrigeration  
R290 built in unit  
Available with all the other refrigerant in use

**AVAILABLE VERSIONS**  
**Refrigerated Understorage**  
Celle refrigerate



# GOLDWINE

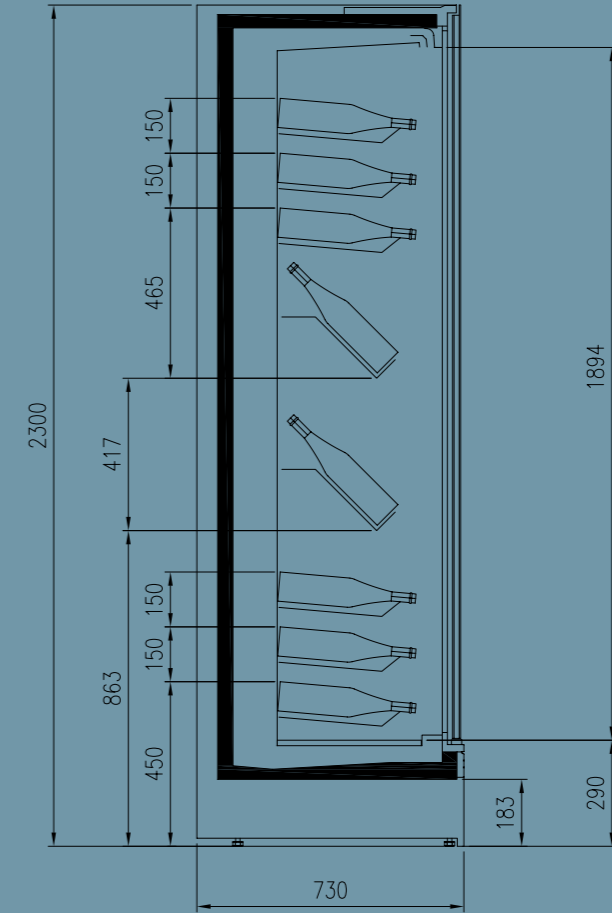

# TECH SPECS

## COMMERCIAL CATEGORIES



## TECHNICAL FEATURES



Remote



Plug-in



Ventilated

## AVAILABLE DIMENSIONS

L: 1250 - 1875

## REFRIGERANT

Thermostatic expansion valve

for all the refrigerant in use

Co2 Refrigeration

R290 built in unit

Available with all the other refrigerant in use



# GENOVA BT H180

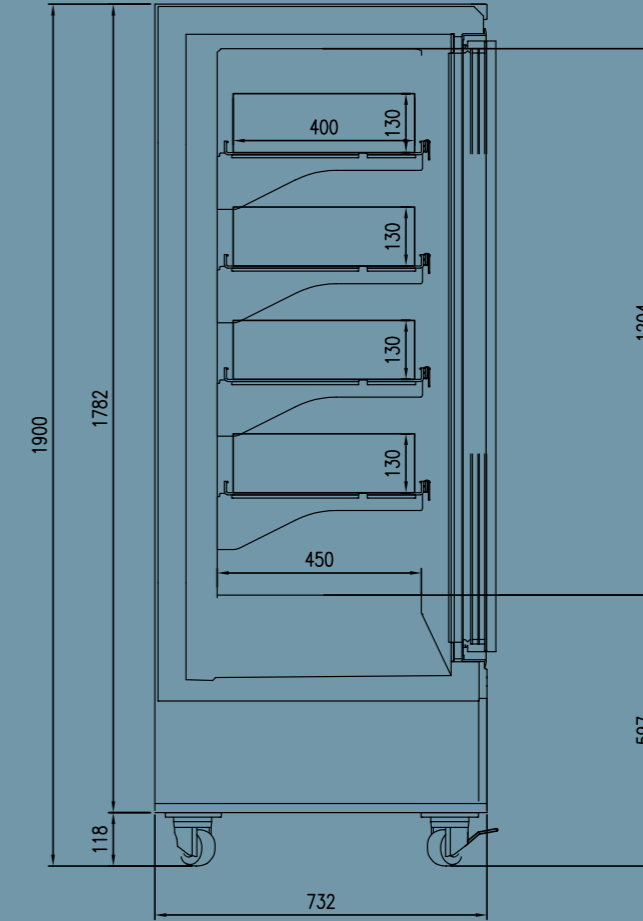

TECH SPECS

## COMMERCIAL CATEGORIES



## TECHNICAL FEATURES



Plug-in



Low consumption fan



LED lighting



Propane refrigerant gas

## AVAILABLE DIMENSIONS

1 Door x 780  
H. 180

## REFRIGERANT

Thermostatic expansion valve for all the refrigerant in use. R290 built in unit





# ISEO TN

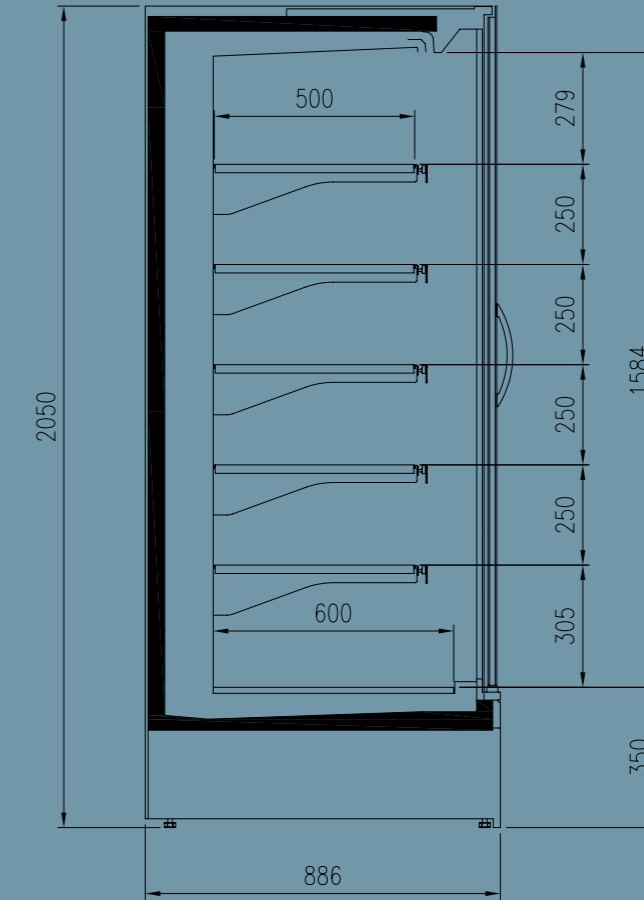

# TECH SPECS

## COMMERCIAL CATEGORIES



## TECHNICAL FEATURES

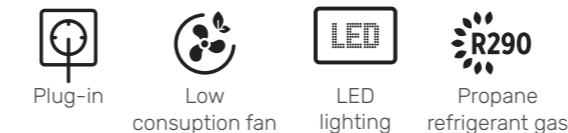

## AVAILABLE DIMENSIONS

L: 625 - 937 - 1250 - 1875 - 2500 - 3750  
 D: 68 - 75 - 90  
 H: 150 - 165 - 205 - 216

## REFRIGERANT

Thermostatic expansion valve  
 for all the refrigerant in use  
 Co2 Refrigeration  
 R290 built in unit  
 Available with all the other refrigerant in use

## AVAILABLE VERSIONS

**Waterloop**



# ISEO BT

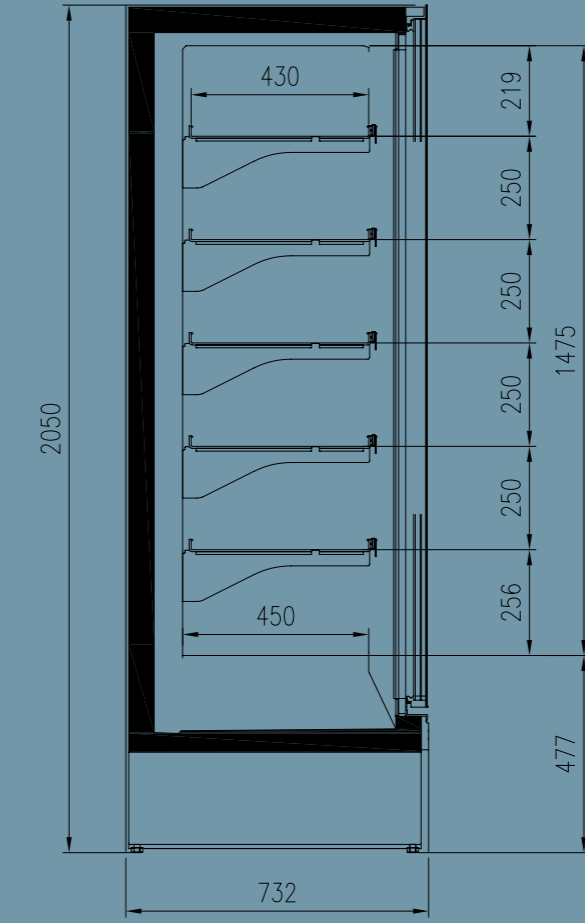

# TECH SPECS

### COMMERCIAL CATEGORIES



### TECHNICAL FEATURES



Plug-in



Low consumption fan



LED lighting



Propane refrigerant gas

### AVAILABLE DIMENSIONS

L: 625 - 780 - 1250 - 1560 - 1875 - 2340  
D: 75 - 90  
H: 205 - 216

### REFRIGERANT

Thermostatic expansion valve for all the refrigerant in use  
Co2 Refrigeration  
R290 built in unit  
Available with all the other refrigerant in use

### AVAILABLE VERSIONS

**Waterloop**



# ZERMATT

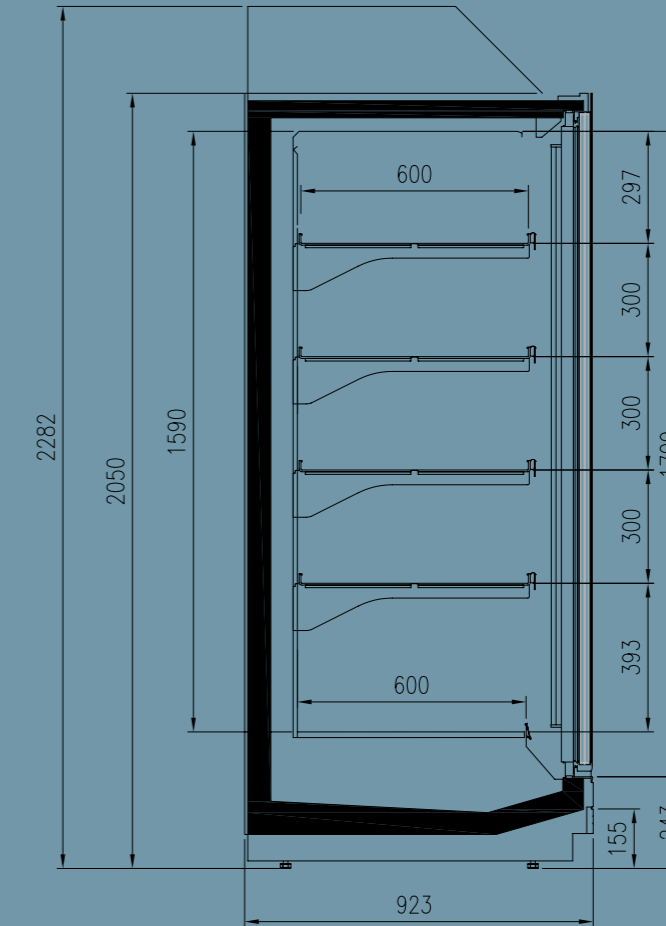

# TECH SPECS

### COMMERCIAL CATEGORIES



### TECHNICAL FEATURES



Remote



Ventilated

### AVAILABLE DIMENSIONS

L: 785 - 1560 - 2341 - 3120 - 3899

D: 90

H: 205 - 216

### REFRIGERANT

Thermostatic expansion valve

for all the refrigerant in use

Co2 Refrigeration

R290 built in unit

Available with all the other refrigerant in use



# ARONA

### COMMERCIAL CATEGORIES



### TECHNICAL FEATURES



Remote    Ventilated

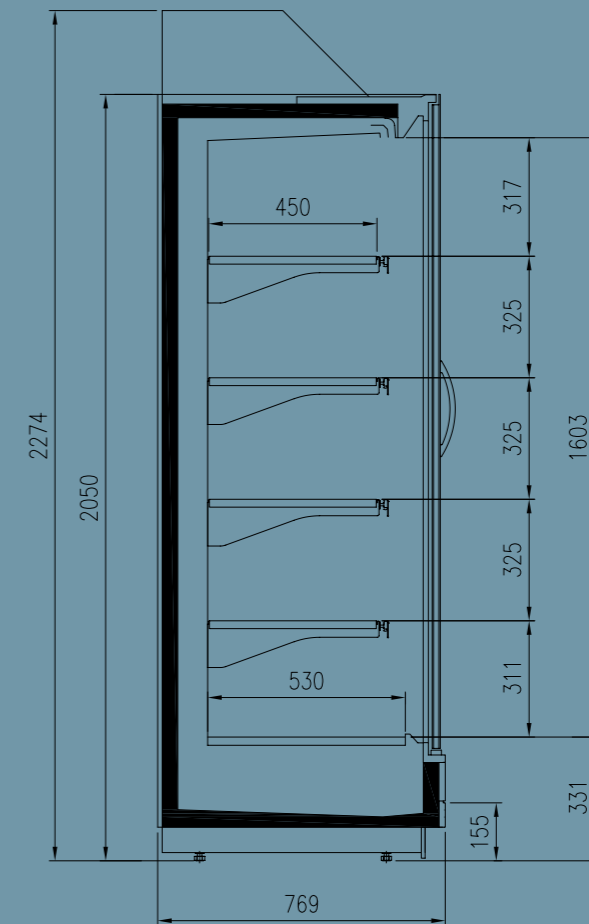

### AVAILABLE DIMENSIONS

L: 1250 - 1875 - 2500 - 3750  
D: 75 - 90 - 100 - 110  
H: 205 - 216

### REFRIGERANT

Thermostatic expansion valve  
for all the refrigerant in use  
Co2 Refrigeration  
R290 built in unit  
Available with all the other refrigerant in use



# EXCELSIOR

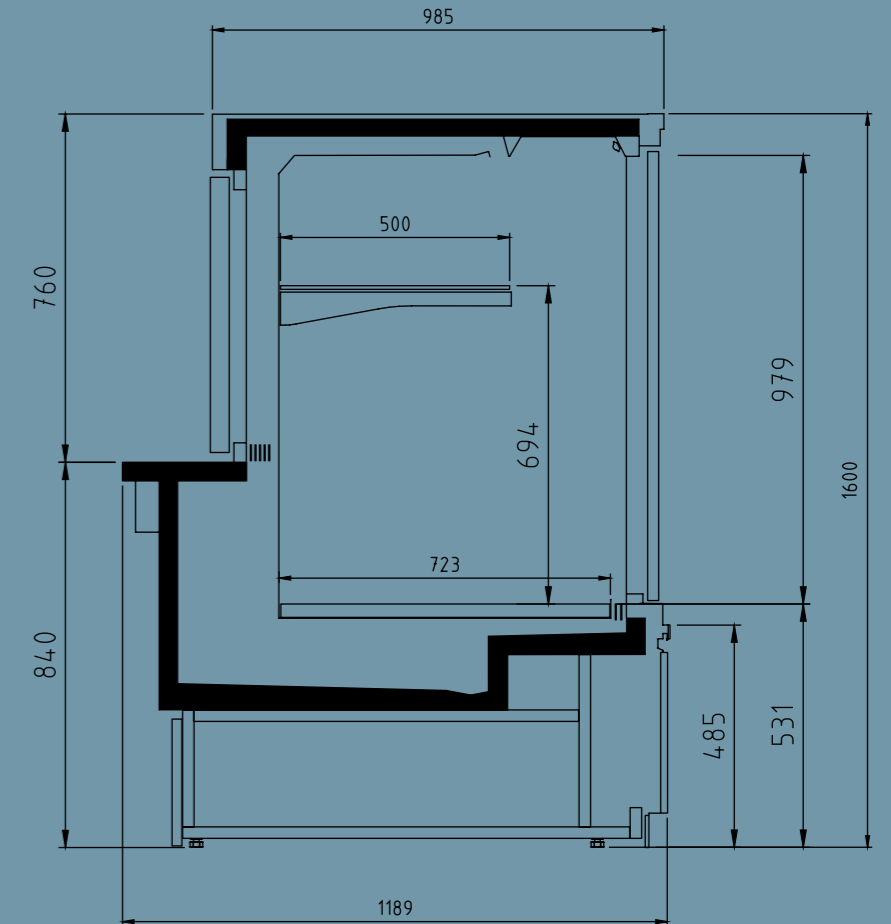
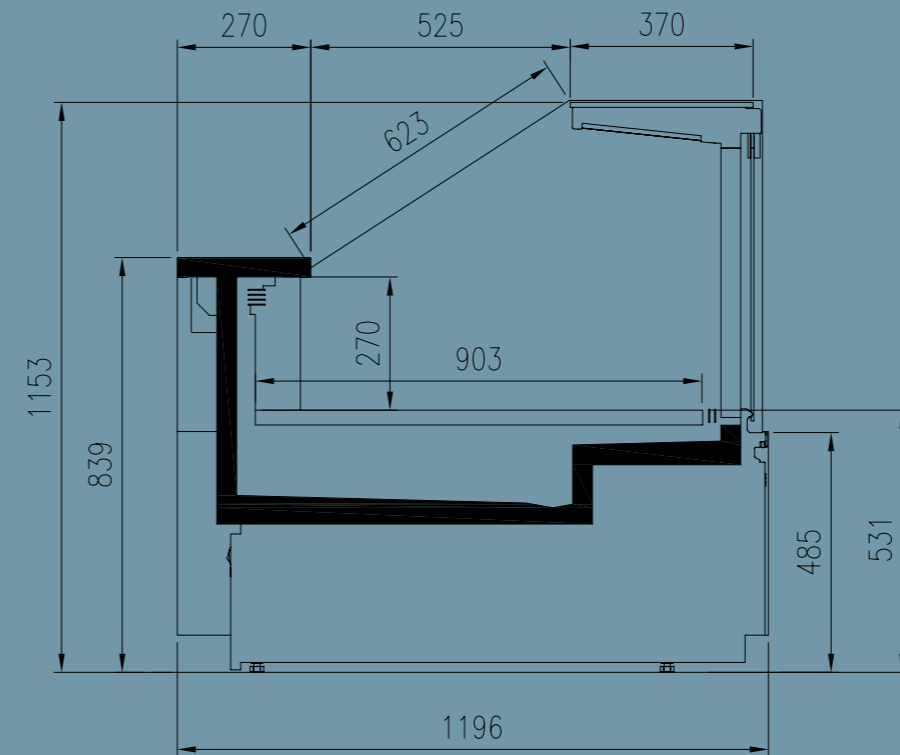

TECH SPECS

### COMMERCIAL CATEGORIES



### TECHNICAL FEATURES

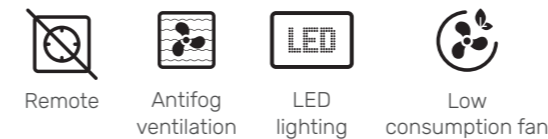

### AVAILABLE DIMENSIONS

L: 937 - 1250 - 1875 - 2500 - 3125 - 3750  
90° INT/ EXT - 45° INT/ EXT

### REFRIGERANT

Thermostatic expansion valve for all the refrigerant in use  
Co2 Refrigeration

### AVAILABLE VERSIONS

- Double Static** - Doppio Statico
- Hot Section** - Tavola Calda
- Fish** - Pesce
- Pastry** - Pasticceria
- Bread** - Pane

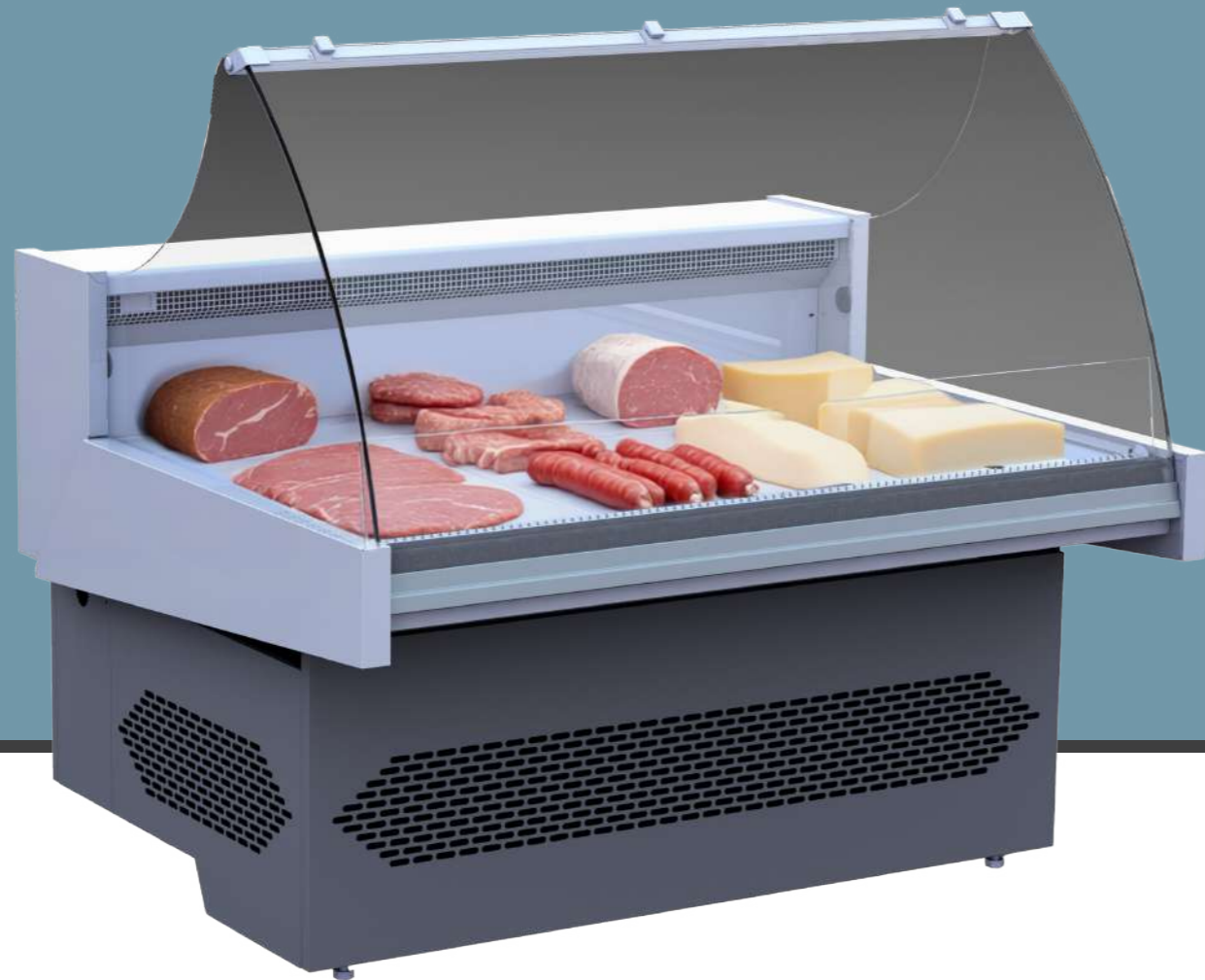

# CLICK

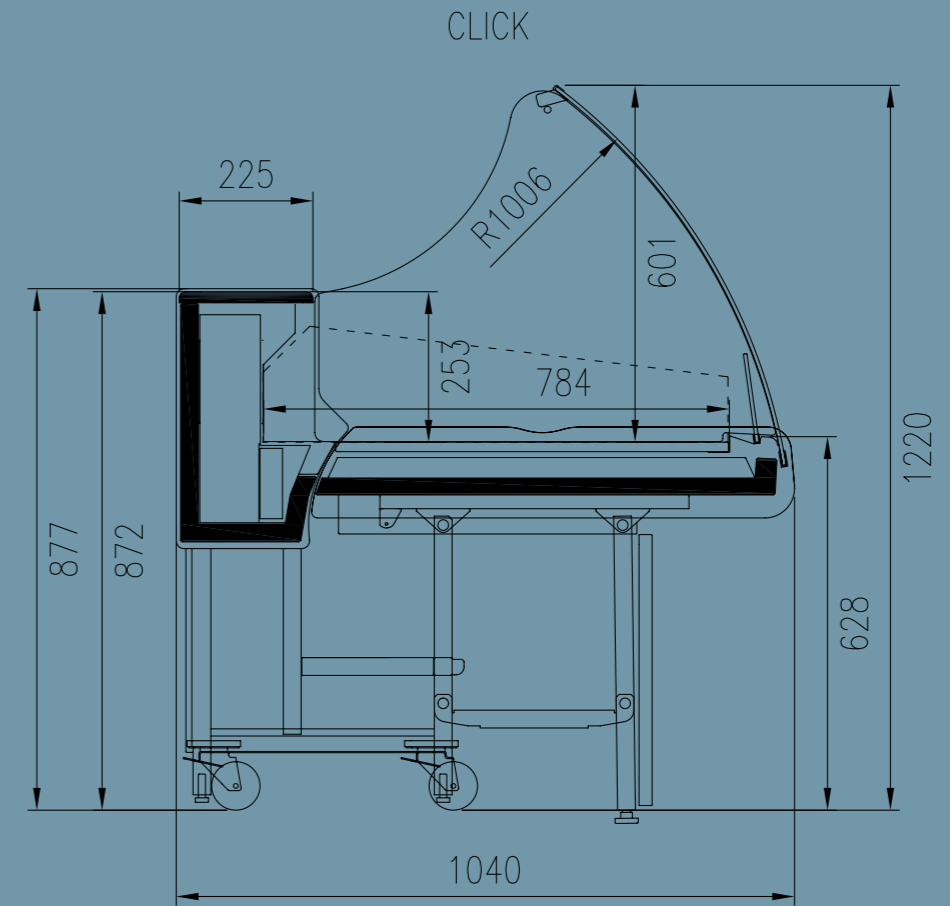

### COMMERCIAL CATEGORIES



### TECHNICAL FEATURES



Plug-in



Low consumption fan

### AVAILABLE DIMENSIONS

L: 1250 - 1875

### REFRIGERANT

Thermostatic expansion valve for all the refrigerant in use

Co2 Refrigeration

R290 built in unit

Available with all the other refrigerant in use

### AVAILABLE VERSIONS

Self Service Lighting - Illuminazione

# TECH SPECS



# PANAREA HD

**B** A ↑ G

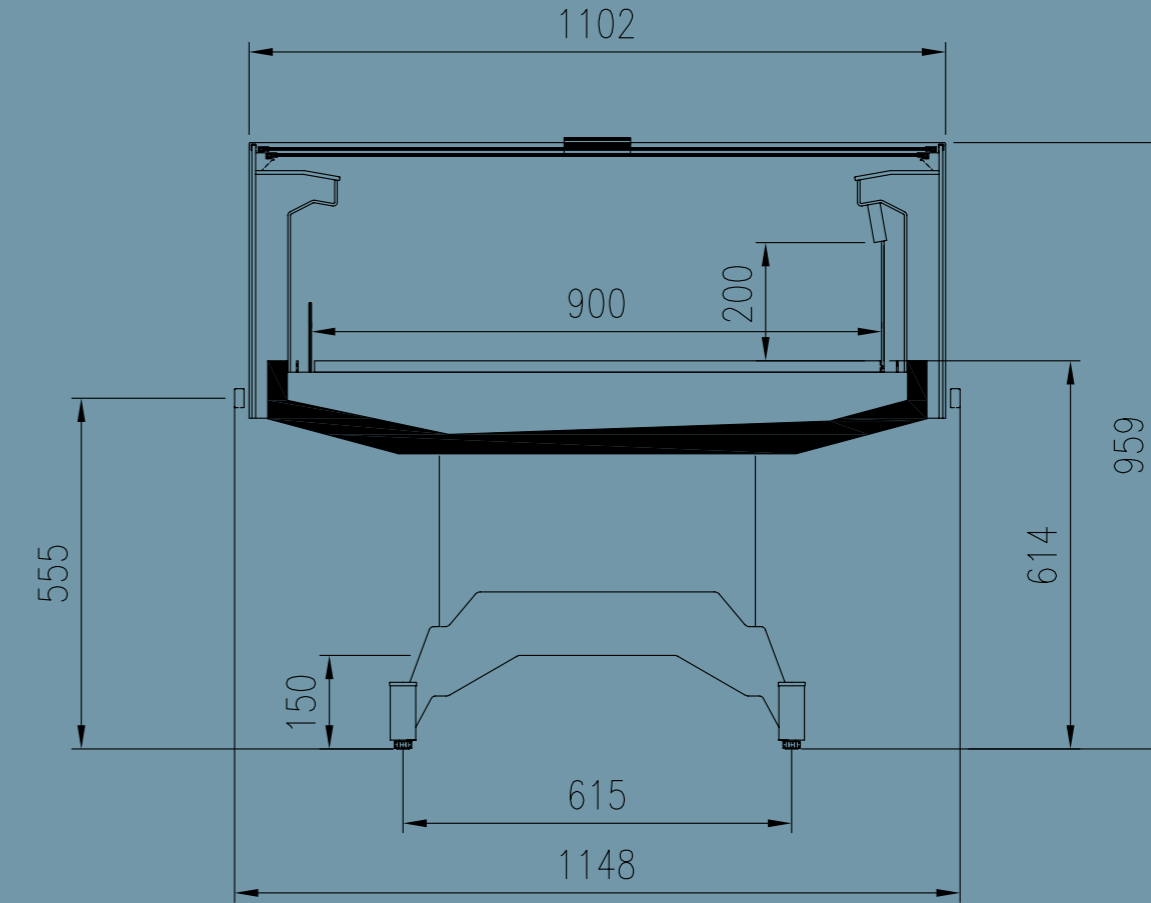

**TECH SPECS**

### COMMERCIAL CATEGORIES



### TECHNICAL FEATURES



### AVAILABLE DIMENSIONS

L: 937 - 1250

### REFRIGERANT

Thermostatic expansion valve for all the refrigerant in use  
 Co2 Refrigeration  
 R290 built in unit  
 Available with all the other refrigerant in use

### AVAILABLE VERSIONS

**With Sliding Doors** - Con chiusure scorrevoli



# PANAREA BMM

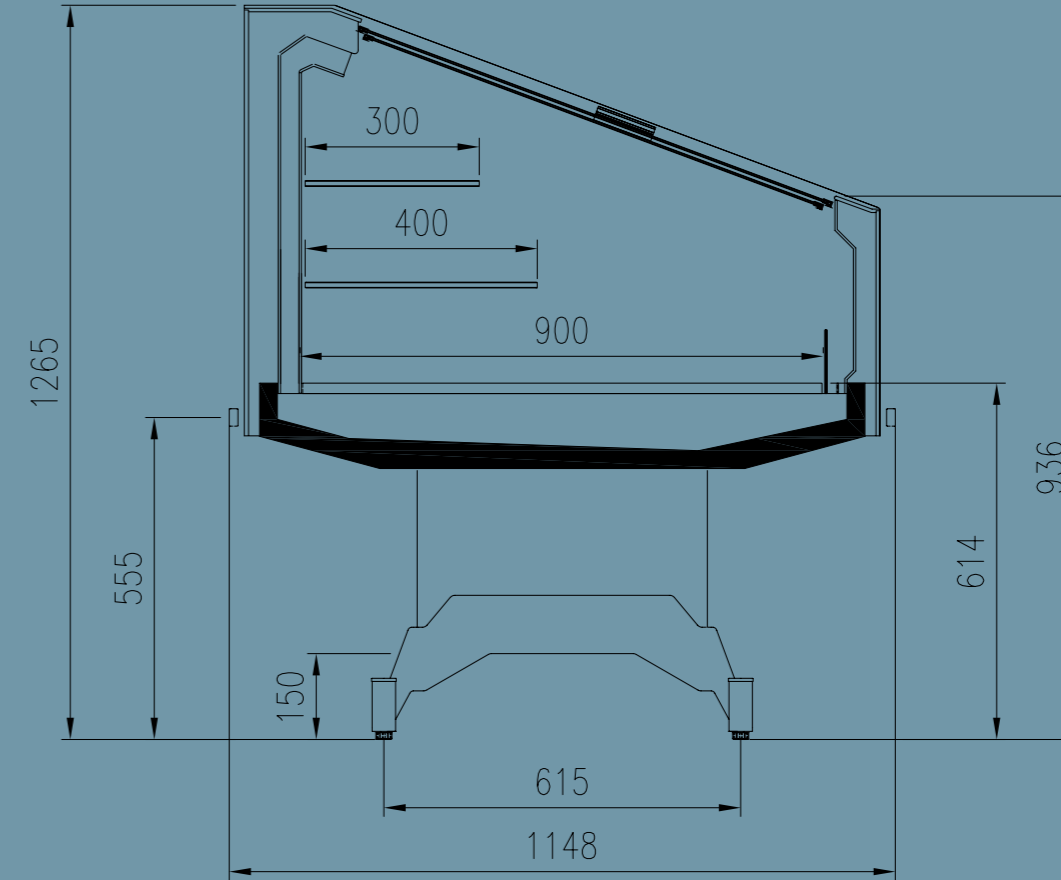

TECH SPECS

### COMMERCIAL CATEGORIES



### TECHNICAL FEATURES



### AVAILABLE DIMENSIONS

L: 937 - 1250

### REFRIGERANT

Thermostatic expansion valve for all the refrigerant in use  
Co2 Refrigeration  
R290 built in unit  
Available with all the other refrigerant in use

### AVAILABLE VERSIONS

**With Sliding Doors** - Con chiusure scorrevoli



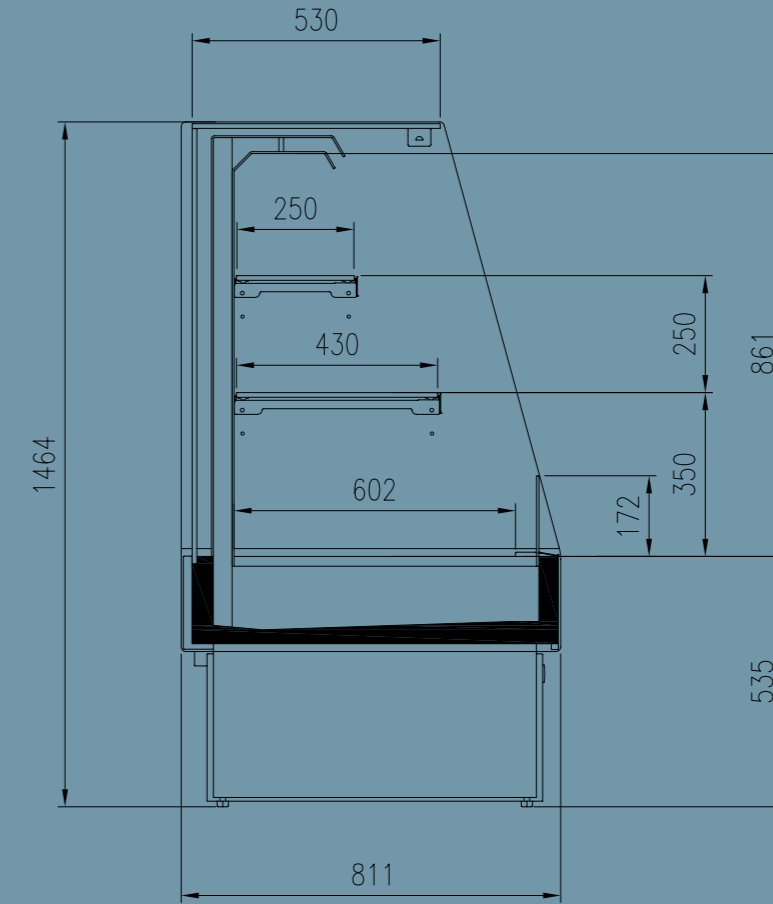

TECH SPECS

# PANGEA

### COMMERCIAL CATEGORIES



### TECHNICAL FEATURES



### AVAILABLE DIMENSIONS

L: 937 - 1250

### REFRIGERANT

Thermostatic expansion valve  
for all the refrigerant in use  
Co2 Refrigeration  
R290 built in unit  
Available with all the other refrigerant in use



# STAR

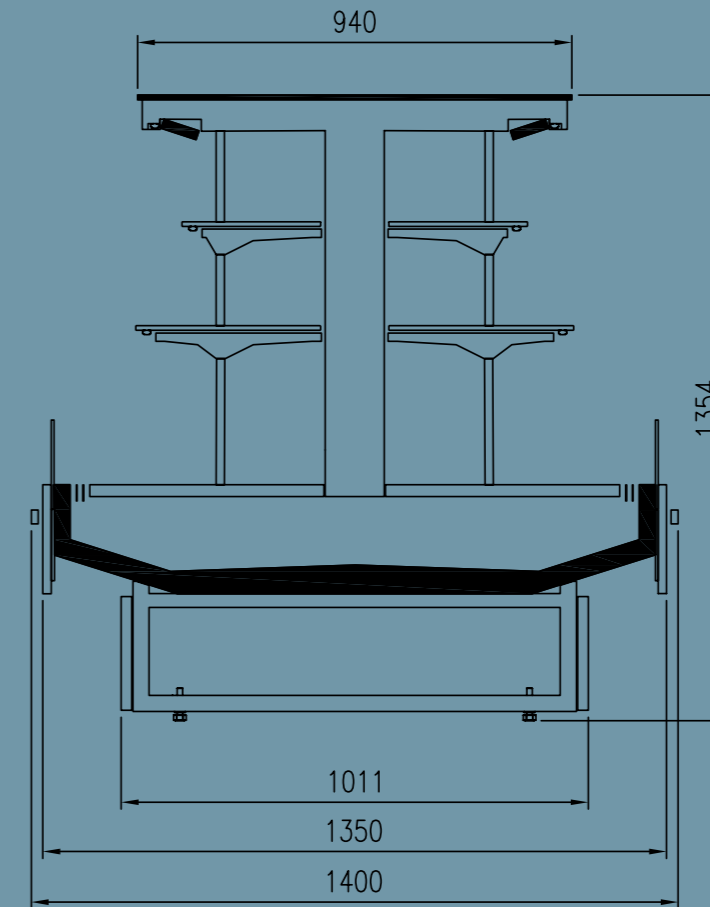

# TECH SPECS

### COMMERCIAL CATEGORIES



### TECHNICAL FEATURES



Plug-in



Low consumption fan



Propane refrigerant gas

### AVAILABLE DIMENSIONS

L: 1250

1964 - 2025  
61 years

*pastorfrigor*

 **pastorfrigor**  
TECHNOLOGY COMES TO HAND

 **pastorkalt**  
INNOVATIVE TECHNOLOGY - GREEN FUTURE

 **pannelli isolanti**  
GET COOL WITH ITALIAN COLD ROOMS

 **pastorproject**  
LOVE IS NOT NECESSARILY WARM

**Pastorfrigor S.p.A.**

Reg. Gabannone, 4 Z.I. • 15033 Terruggia (AL) • Italy | Phone +39 0142 433 711 • Fax +39 0142 433 701 | P.IVA/VAT IT00578270068

[www.pastorfrigor.it](http://www.pastorfrigor.it)



**Pastorfrigor S.p.A.**

Reg. Gabannone, 4 Z.I. • 15033 Terruggia (AL) • Italy

Phone +39 0142 433 711 • Fax +39 0142 433 701

P.IVA/VAT IT00578270068

[www.pastorfrigor.it](http://www.pastorfrigor.it)